

# HB02 LED HIGH BAY



**\* Product features:**

- High-quality LEDs provided by Samsung/ Seoul Semiconductor/ Nichia/ Lumiled with excellent performance
- High efficacy up to 105 lm/W
- Pure aluminum fin heatsink design with light weight and perfect heat dissipation
- Aluminum lampshade with heat resistant silver coating
- CE, KC certified
- Long lifespan: 25,000 hours, saving the maintenance cost

**\* Applications:**

- Factories, storages, playgrounds, large precincts, etc.



## PRODUCT DETAILS

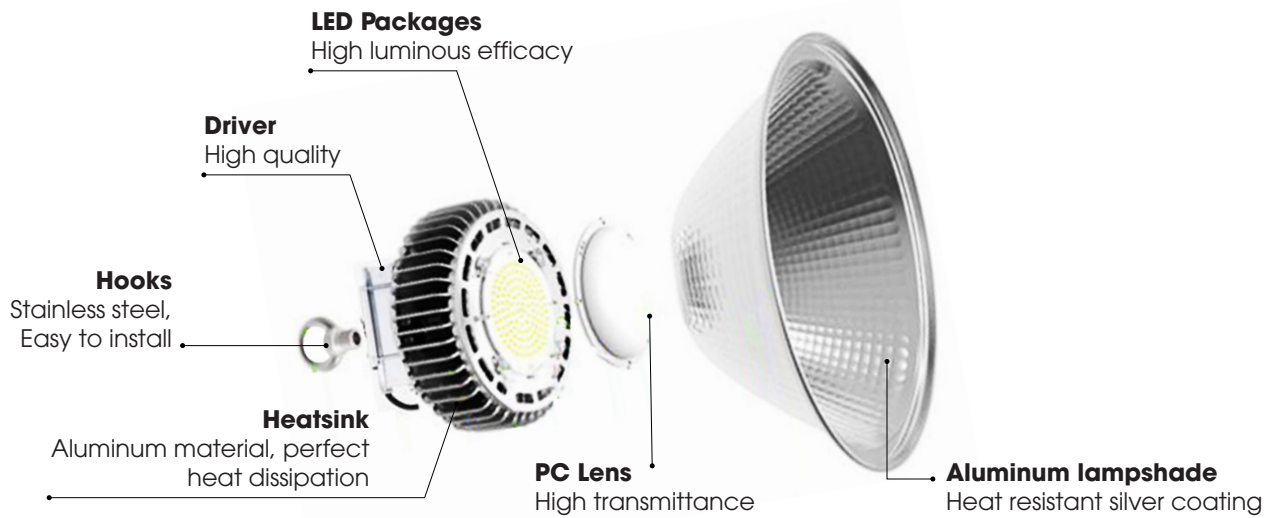

## PRODUCT SPECIFICATIONS

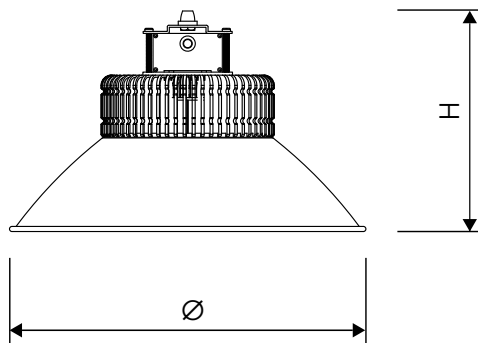

Model	Dimension ØxH (mm)	Power (W)	Voltage (V)	Power factor	Luminous flux (lm)	Luminous Efficacy (lm/W)	CCT (K)	CRI (Ra)	Beam angle (°)	Lifespan (hrs)
HB02 350/50W	350x240	50	120/220÷240/100÷277	0.9	5000/5250	100/105	3000/5000/6500K	80	90	25,000
HB02 350/70W	350x240	70	120/220÷240/100÷277	0.9	7000/7350	100/105	3000/5000/6500K	80	90	25,000
HB02 430/100W	450x280	100	120/220÷240/100÷277	0.9	10000/10500	100/105	3000/5000/6500K	80	90	25,000
HB02 430/120W	450x280	120	120/220÷240/100÷277	0.9	12000/12600	100/105	3000/5000/6500K	80	90	25,000
HB02 430/150W	450x280	150	120/220÷240/100÷277	0.9	15000/15750	100/105	3000/5000/6500K	80	90	25,000
HB02 500/200W	490x350	200	120/220÷240/100÷277	0.95	20000/21000	100/105	3000/5000/6500K	80	90	25,000

**Capacity: 2.0 million pieces per year**

**Customizable:** Power (50/70/100/120/150/200W), Voltage (120/220÷240/100÷277), lm/W (100/105), CCT (3000/5000/6500K), Driver (non isolation/ isolation), lifespan, etc.

## LUMINOUS INTENSITY DISTRIBUTION

HB02 50W

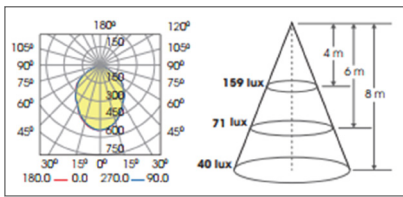

HB02 70W

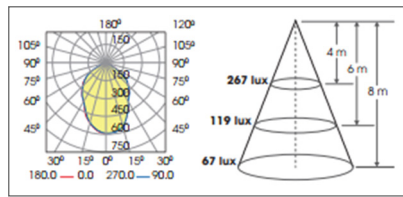

HB02 100W

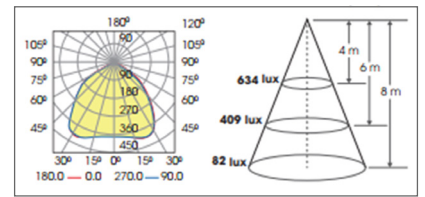

HB02 120W

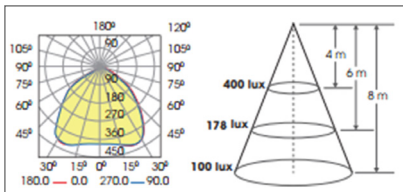

HB02 150W

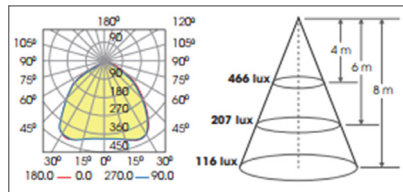

HB02 200W

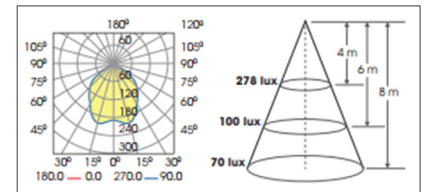

## PACKING AND TRANSPORTATION



Type of lamps	Quantity/ carton box (pcs)	Estimated quantity/ 20'DC (pcs)	Estimated quantity/ 40'HC (pcs)
HB02 350_50/70W	2	4170	9578
HB02 430_100/120/150W	2	2422	5562
HB03 500_200W	2	1580	3630
Lampshade 350	10	16740	38430
Lampshade 430	10	8590	19740
Lampshade 500	10	7590	17440

Customizable according to customer's request



Exported market: South Korea, EU, etc



**RANG DONG LIGHT SOURCE AND VACUUM FLASK JOINT STOCK COMPANY**

Add: 87- 89 Ha Dinh Street, Thanh Xuan, Hanoi, Vietnam

Tel: (84-24) 3 858 4310 / 3 858 4165

Fax: (84-24) 3 858 5038

Email: [export@rangdong.com.vn](mailto:export@rangdong.com.vn)



Specifications are subject to change without prior notice